

versar.com.sg

VE MODEL

VE MODEL

Single Stage,
Horizontal, End Suction
Norm Centrifugal Pumps



VERSAR®

General Information

Discharge Flange	: DN 32 - DN 250
Capacity	: 1750 m ³ /h
Head	: 160 m
Speed	: 1500 - 3600 rpm
Liquid Temperature	: -20°C to + 140°C*
Pressure (Pmax)	: 16 bar
(Pmax: Suction Pressure + Shut Off Head)	
Frequency	: 50 - 60 Hz

(*): Optional

According to different voltage and operating voltage, the frequency and voltage may vary. Can be shaped according to customer request.

Depending on the type of liquid, operating temperature and pressure. The pump material changes. Please contact our company for detailed information.

Handled Liquids

Clean or slightly dirty, non-abrasive, low-viscosity fluids

Applications

Petro-chemical
Building Systems
Iron and Steel Industries

Power Plants
Food and Beverage Industries
Mining

Fire fighting Industrial
water supply

Design Features

- VE series pumps has designed for pumping non-abrasive and small particulars liquids.
- VE series pump has just one impeller, pump and motor is connecting by coupling. It gives yours avantages for easy disassembling.
- Pump DIMENSIONS are acceptable EN 733/DIN24255 standard.
- Input and Output Flange Diamesions are acceptable ISO 1092-2/PN 16.
- VE series is off the wheel and wheel balancing holes in the wings to minimize ta axial loads, dynamic loads are balanced within.
- Sealing is provided by gland packing. Sealing is provided by also mechanical seal as customer request.
- Easy dissasamble to pump and change impeller, bearings and seals.
- All impellers are balanced statically and dynamically according to ISO 1940 class 6.3.
- Direction of rotation is clockwise viewed from driver end.

Pump Code

Pump code

VE60-315. VE 65-315BG. VE65-315SG.

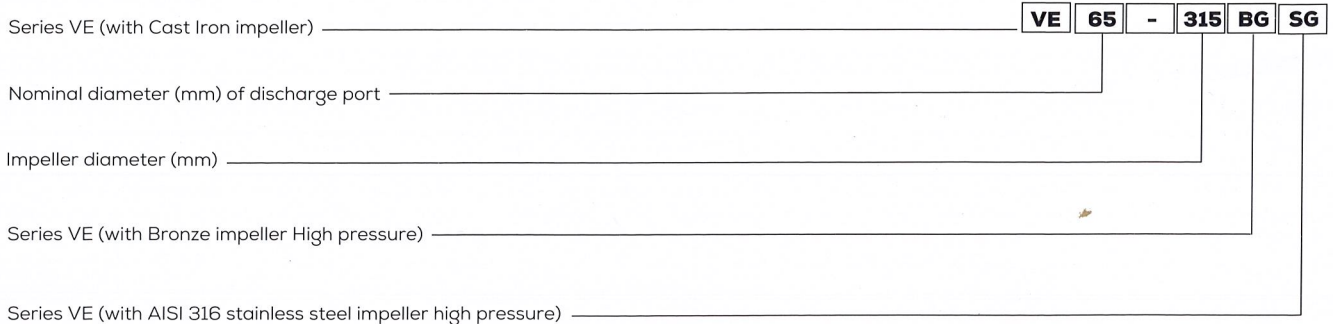

Material Options

VE MODEL

Part List	0.6025	0.7040	1.0619	1.4308	1.4309	1.4408	1.4409	1.4500	1.4517	1.4469	1.4317	2.1050.01	2.1050.01	1.0503	1.4021	1.4301	1.4306	1.4401	1.4404	1.4462	
Volute	●	○	○	○	○	○	○	○	○	○	○	○	○								
Seal Box	●	○	○	○	○	○	○	○	○	○	○	○	○								
Impeller	●	○	○	○	○	○	○	○	○	○	○	●	○								●
Shaft														○	●	○	○	○	○	○	○
Bearing Box	●	○																			
Wear Ring	○	○	○	○	○	○	○	○	○	○	○	○	○								
Shaft Sleeve														○	○	○	○	○	○	○	○
Mech. Seal	EN 12756/DIN24960																				

(*) Different brand and type mechanical seal can be use according to customer request.

DESCRIPTIONS	DIN 17007	EN-DIN	ASTM
CAST IRON	0.6025	A 48 Class 40-B	GJL-250 (GG 25)
NODULAR CAST IRON	0.7040	A 536 Gr. 60-40-18	GJS-400-15 (GGG 40)
CAST STEEL	1.0619	A 216 Gr. WCB	GP240GH (GS-C 25)
CHROME NICKEL CAST STEEL	1.4308	A 351/743/744 Gr. CF8	G-X5 Cr Ni 19-10
CHROME NICKEL CAST STEEL (L.C.)	1.4309	A 351/743/744 Gr. CF3	G-X2 Cr Ni 19-11
CHROME NICKEL MOLYBDENUM CAST STEEL	1.4408	A 351/743/744 Gr. CF8M	G-X5 Cr Ni Mo 19-11-2
CHROME NICKEL MOLYBDENUM CAST STEEL (L.C.)	1.4409	A 351/743/744 CF3M	G-X2 Cr Ni Mo 19-11-2
AUSTENITIC CAST STEEL	1.4500	A 351/743/744 (CN7M)	G-X2 Cr Ni Mo Cu Nb 25-20
AUSTENITIC - FERRITIC CAST STEEL(DUBLEX)	1.4517	A 890 Gr. 1B (CD4MCuN)	G-X2 Cr Ni Mo Cu N 25-6-3-3
AUSTENITIC - FERRITIC CAST STEEL(SUPER.DUBLEX)	1.4469	A 890 Gr. 5A (CE3MN)	G-X2 Cr Ni Mo N 26-7-4
MARTENZITIC STAINLESS CAST STEEL	1.4317	A 351/743/744 (CA6NM)	G-X4 Cr Ni 13-4
CAST BRONZE (TIN ALLOY)	2.1050.01	B 584 C 90700	G-Cu Sn 10
CAST BRONZE (NICKEL ALLOY)	2.0975.01	B 148 C 95800	G-CU Al 10 Ni
CARBON STEEL	1.0503	A 29/108/576 1045	C 45
CHROME STEEL	1.4021	A 276 Type 420	X20 Cr13
CHROME STEEL	1.4301	A 276 Type 304	X5 Cr Ni 18-10
CHROME NICKEL STEEL (L.C.)	1.4306	A 276 Type 304L	X2 Cr Ni 19-11
CHROME NICKEL MOLYBDENUM STEEL	1.4401	A 276 Type 316	X5 Cr Ni Mo 17-12-2
CHROME NICKEL MOLYBDENUM STEEL(L.C.)	1.4404	A 276 Type 316L	X2 Cr Ni Mo 17-12-2
DUPLEX STEEL	1.4462	A 276 S 31803	X2 Cr Ni Mo N 22-5-3

Selection Charts

VE MODEL

Performance curves at 1500 rpm

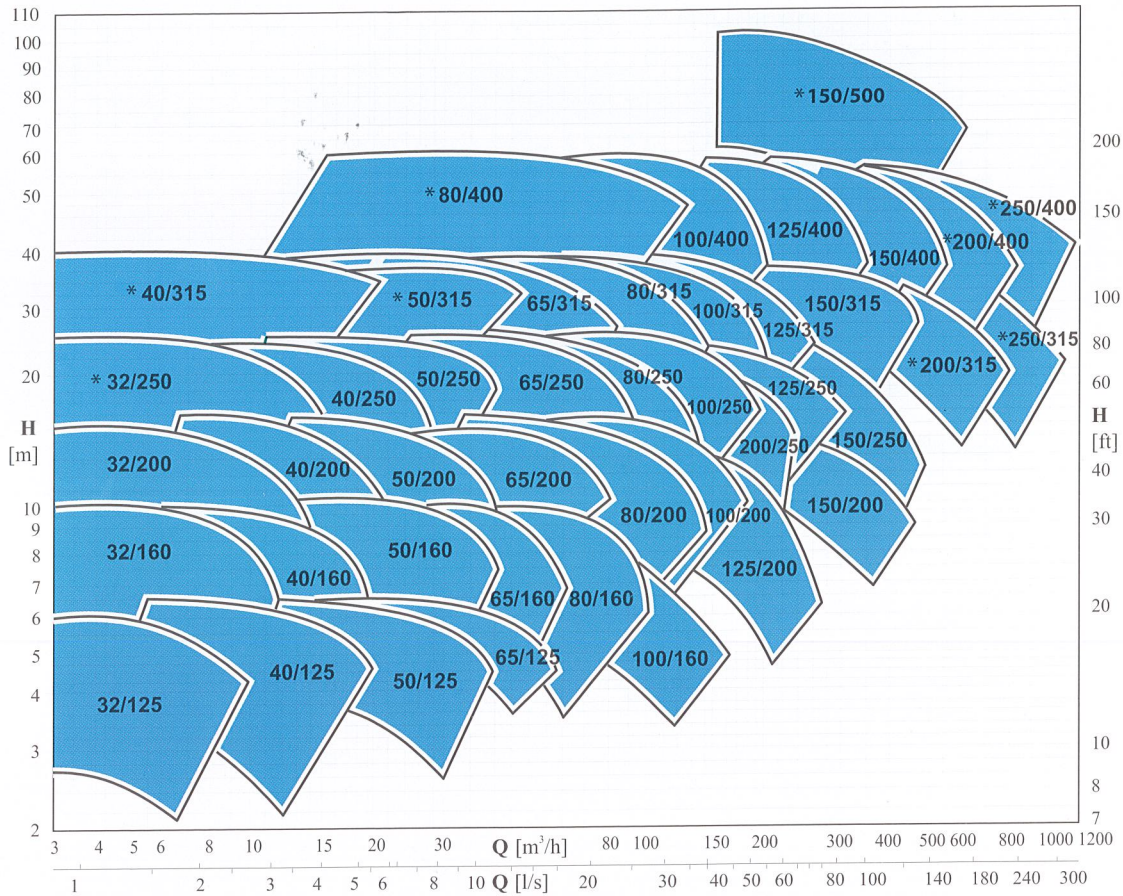

1500 rpm 1500rpm (50 Hz)

Performance curves at 3000 rpm

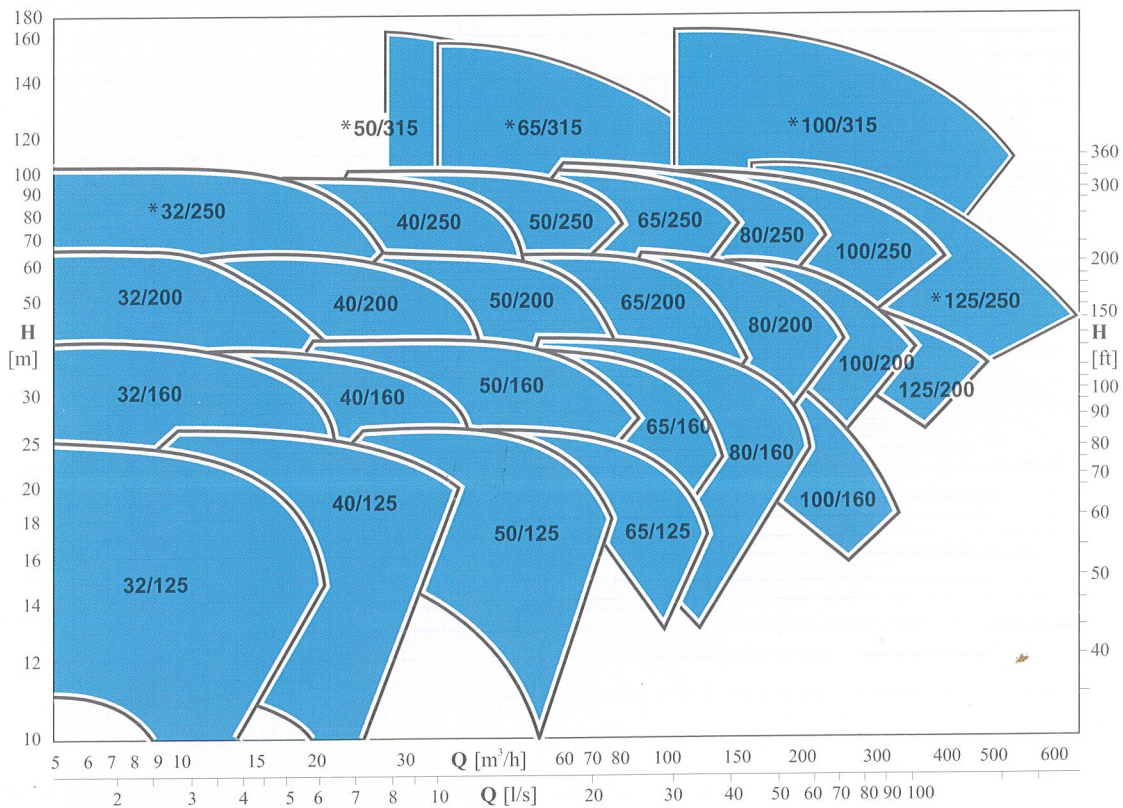

3000 rpm 3000rpm (50 Hz)

* Parameters not covered by EN733 (DIN24255): see performance fields.

Sectional View

VE MODEL

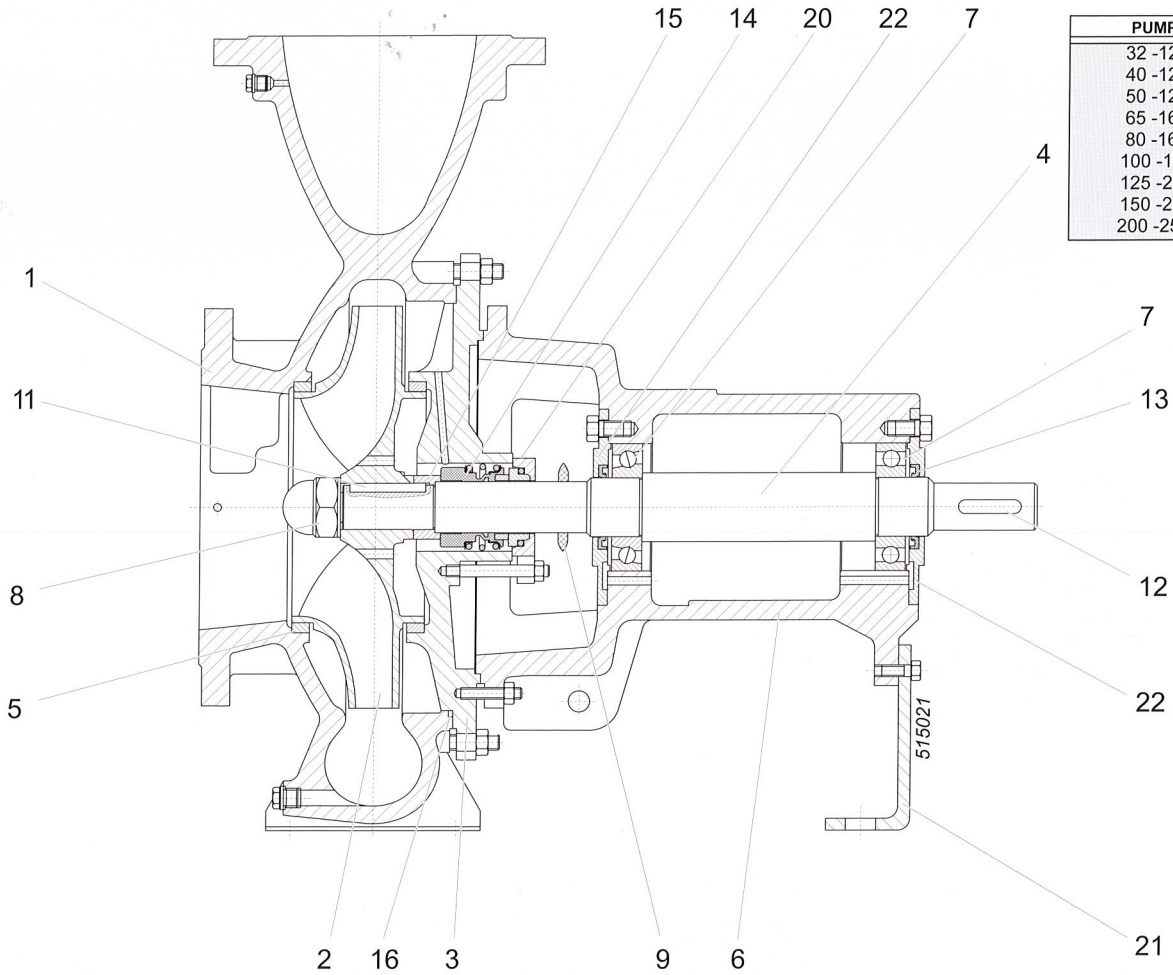

PUMP TYPE	
32	-125+250
40	-125+315
50	-125+315
65	-160+315
80	-160+400
100	-160+400
125	-200+400
150	-200+400
200	-250+400

Pos.	Parts	Materials
1	Pump casing	Cast iron
2	Impeller	Cast iron (*)
3	Connection support	Cast iron
4	Shaft	Stainless steel
5	Wear ring	Cast iron
5	Wear ring	Gunmetal
6	Support	Cast iron
7	Bearing	-
8	Nut	Stainless steel
9	Water retainer ring	Nitrile rubber
11	Feather key	Stainless steel
12	Feather key	Steel
13	Seal ring	Nitrile rubber
14	Mechanical seal	Silicon carbide/silicon carbide
15	Shaft spacer sleeve	Stainless steel
16	OR seal	Nitrile rubber
20	Cover mechanical seal	Cast iron
21	Duck foot pedestal	Steel
22	Cover bearing	Cast iron

Screws and nuts in stainless steel.

* In AISI 316 for the VE.../...G versions

Pump DIMENSIONS

VE - 2P / 3000Rpm

COUPLINGS WITH STANDARDIZED ENCLOSED ELECTRIC MOTORS

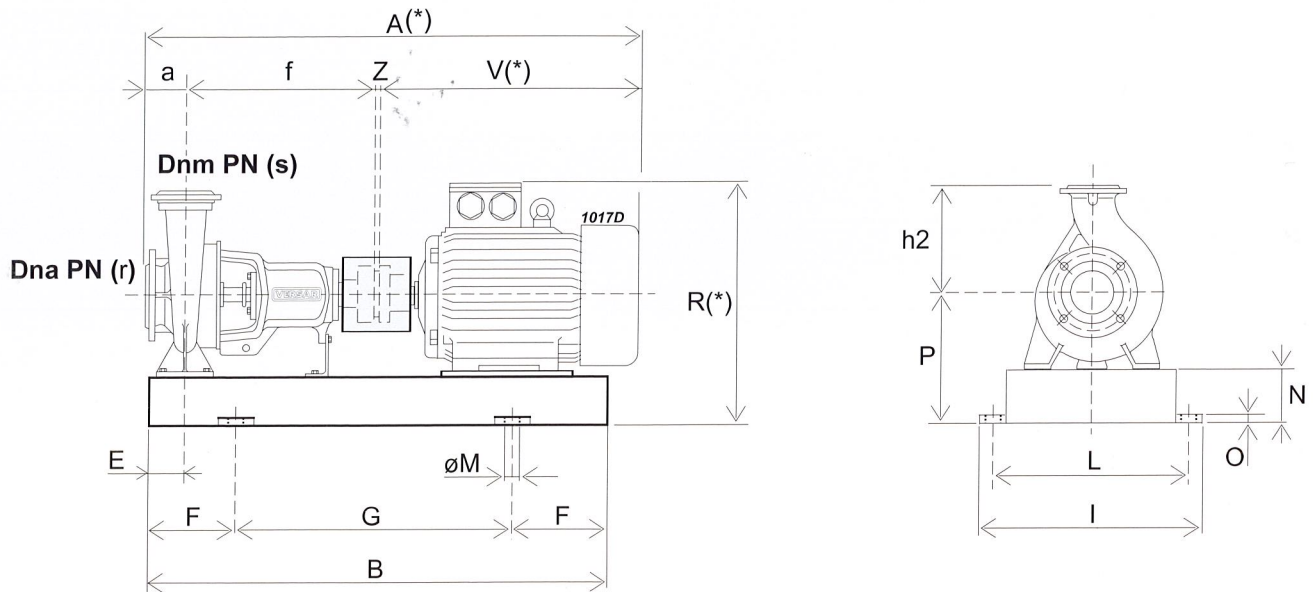

Pump Type		Motor		BGAN	A *	B	E	F	G	I	L	M	N	O	P	R *	V *	Z	a	f	h2	r	s	Weight	
Type	DNa	DNm	[kW]	Type	[mm]																				
	[mm]	[mm]	kW		Size Grand.																				
VE32-125	50	32	1,1	80M	1001/CA	724	689	70	100	489	340	290	0	65	38	177	322	280	4	80	360	140	16	16	51
VE32-125	50	32	1,5	90S	1002/CA	759	710	70	100	510	340	290	0	65	38	177	332	315	4	80	360	140	16	16	64
VE32-160	50	32	2,2	90L	1004/CA	784	735	70	100	535	390	340	0	65	38	197	352	340	4	80	360	160	16	16	67
VE32-160	50	32	3	100L	1005/CA	819	767	70	100	567	390	340	0	65	38	197	377	375	4	80	360	160	16	16	76
VE32-160	50	32	4	112M	1006/CA	844	774	70	100	574	390	340	0	65	38	197	387	400	4	80	360	160	16	16	82
VE32-160	50	32	5,5	132S	1007/CA	909	803	60	100	618	415	365	0	65	38	197	417	465	4	80	360	160	16	16	111
VE32-160	50	32	7,5	132S	1007/CA	909	803	60	100	618	415	365	0	65	38	197	417	465	4	80	360	160	16	16	111
VE32-200	50	32	5,5	132S	1008/CA	909	818	70	100	618	415	365	0	80	38	240	460	465	4	80	360	180	16	16	114
VE32-200	50	32	7,5	132S	1008/CA	909	818	70	100	618	415	365	0	80	38	240	460	465	4	80	360	180	16	16	114
VE32-200	50	32	11	160M	1009/DA	1052	937	70	100	737	465	415	0	80	38	240	505	608	4	80	360	180	16	16	150
VE32-250	50	32	11	160M	1014/DA	1072	950	82,5	100	750	470	420	0	80	38	260	525	608	4	100	360	225	16	16	179
VE32-250	50	32	18,5	160L	1015/DA	1116	994	82,5	100	794	470	420	0	100	38	280	545	652	4	100	360	225	16	16	205
VE40-125	65	40	1,5	90S	1010/CA	759	710	70	100	510	360	310	0	65	38	177	332	315	4	80	360	140	16	16	66
VE40-125	65	40	2,2	90L	1011/CA	784	735	70	100	535	360	310	0	65	38	177	332	340	4	80	360	140	16	16	66
VE40-125	65	40	3	100L	1150/CA	819	765	70	100	565	360	310	0	65	38	177	357	375	4	80	360	140	16	16	68
VE40-160	65	40	3	100L	1005/CA	819	767	70	100	567	390	340	0	65	38	197	377	375	4	80	360	160	16	16	76
VE40-160	65	40	5,5	132S	1007/CA	909	803	60	100	618	415	365	0	65	38	197	417	465	4	80	360	160	16	16	111
VE40-160	65	40	7,5	132S	1007/CA	909	803	60	100	618	415	365	0	65	38	197	417	465	4	80	360	160	16	16	111
VE40-200	65	40	5,5	132S	1012/CA	929	818	70	150	518	415	365	0	80	38	240	460	465	4	100	360	180	16	16	117
VE40-200	65	40	7,5	132S	1012/CA	929	818	70	150	518	415	365	0	80	38	240	460	465	4	100	360	180	16	16	120
VE40-200	65	40	11	160M	1013/DA	1072	912	60	100	712	465	415	0	80	38	240	505	608	4	100	360	180	16	16	170
VE40-200	65	40	15	160M	1013/DA	1072	912	60	100	712	465	415	0	80	38	240	505	608	4	100	360	180	16	16	170
VE40-250	65	40	11	160M	1014/DA	1072	950	82,5	100	750	470	420	0	80	38	260	525	608	4	100	360	225	16	16	169
VE40-250	65	40	15	160M	1014/DA	1072	950	82,5	100	750	470	420	0	80	38	260	525	608	4	100	360	225	16	16	179
VE40-250	65	40	18,5	160L	1015/DA	1116	994	82,5	100	794	470	420	0	100	38	280	545	652	4	100	360	225	16	16	205
VE40-250	65	40	22	180M	1016/EA	1154	990	82,5	100	790	490	440	0	80	38	260	540	690	4	100	360	225	16	16	245
VE40-250	65	40	30	200L	1017/FA	1224	1075	90,5	200	675	540	490	0	100	42	300	610	760	4	100	360	225	16	16	343
VE40-250	65	40	37	200L	1017/FA	1224	1075	90,5	200	675	540	490	0	100	42	300	610	760	4	100	360	225	16	16	343
VE50-125	65	50	2,2	90L	1004/CA	804	735	70	100	535	390	340	0	65	38	197	352	340	4	100	360	160	16	16	67
VE50-125	65	50	3	100L	1005/CA	839	767	70	100	567	390	340	0	65	38	197	377	375	4	100	360	160	16	16	76
VE50-125	65	50	4	112M	1121/CA	864	774	60	100	574	390	340	0	80	38	212	402	400	4	100	360	160	16	16	80
VE50-125	65	50	5,5	132S	1122/CA	929	793	60	100	593	415	365	0	65	38	197	417	465	4	100	360	160	16	16	83
VE50-160	65	50	4	112M	1018/CA	864	764	60	100	564	415	365	0	80	38	240	430	400	4	100	360	180	16	16	87
VE50-200	65	50	18,5	160L	1155/CA	1116	982	70	100	781,5	465	415	0	80	42	240	505	652	4	100	360	200	16	16	175
VE50-250	65	50	18,5	160L	1015/DA	1116	994	82,5	100	794	470	420	0	100	38	280	545	652	4	100	360	225	16	16	205
VE50-250	65	50	22	180M	1016/EA	1154	990	82,5	100	790	490	440	0	80	38	260	540	690	4	100	360	225	16	16	245
VE50-250	65	50	30	200L	1017/FA	1224	1075	90,5	200	675	540	490	0	100	42	300	610	760	4	100	360	225	16	16	343

Pump DIMENSIONS

VE - 2P / 3000Rpm

COUPLINGS WITH STANDARDIZED ENCLOSED ELECTRIC MOTORS

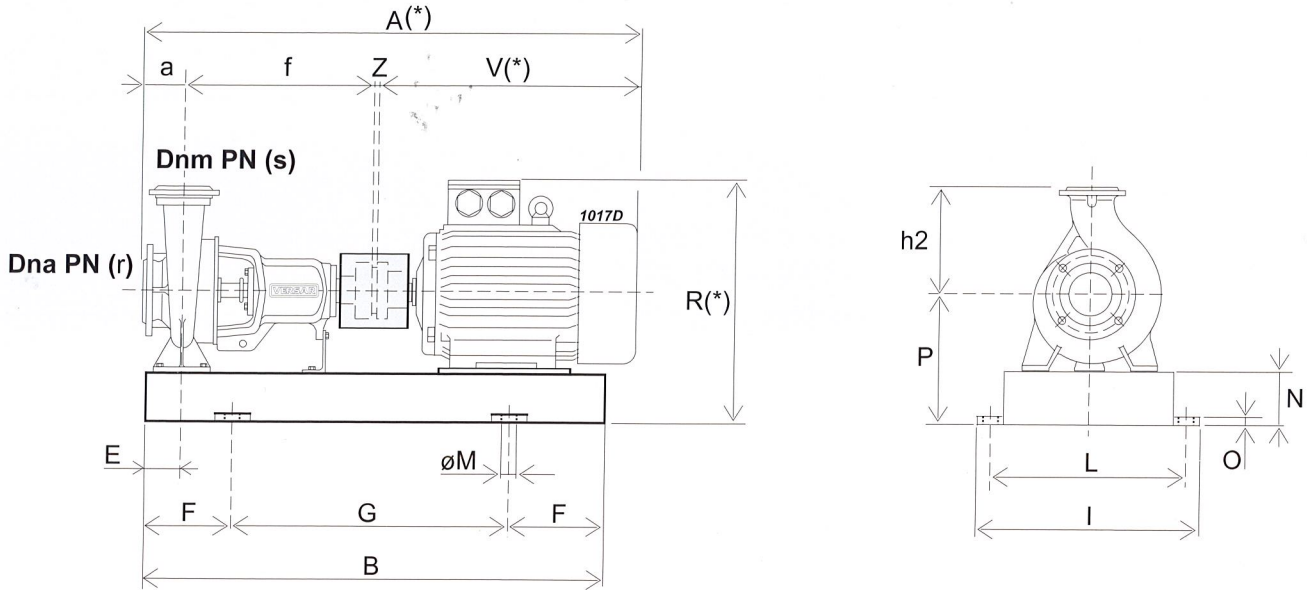

Pump Type		Motor		BGAN	A *	B	E	F	G	I	L	M	N	O	P	R *	V *	Z	a	f	h2	r	s	Weight	
Type	DNa [mm]	DNm [mm]	[kW] kW	Size Grand.	Type	[mm]																			
VE50-250	65	50	37	200L	1017/FA	1224	1075	90,5	200	675	540	490	0	100	42	300	610	760	4	100	360	225	16	16	343
VE50-315	80	50	22	180M	2000/EX	1319	1108	82,5	200	708	520	470	0	100	38	325	605	690	4	125	500	280	16	25	304
VE50-315	80	50	30	200L	2001/FX	1389	1184	82,5	200	784	560	510	0	100	38	325	635	760	4	125	500	280	16	25	360
VE50-315	80	50	37	200L	2001/FX	1389	1184	82,5	200	784	560	510	0	100	38	325	635	760	4	125	500	280	16	25	360
VE50-315	80	50	45	225M	2002/FX	1434	1216	82,5	200	816	605	555	0	100	38	325	660	805	4	125	500	280	16	25	439
VE50-315	80	50	55	250M	2003/GX	1539	1343	77,5	200	943	655	605	0	120	42	370	745	910	4	125	500	280	16	25	539
VE50-315	80	50	75	280S	2004/HX	1614	1374	82,5	250	874	705	655	0	140	42	420	825	985	4	125	500	280	16	25	680
VE50-315	80	50	90	280M	2005/HX	1659	1425	82,5	250	925	705	655	0	140	42	420	825	1030	4	125	500	280	16	25	711
VE65-125	80	65	5,5	132S	1019/CA	929	830	82,5	100	630	430	380	0	80	38	240	460	465	4	100	360	180	16	16	122
VE65-125	80	65	7,5	132S	1019/CA	929	830	82,5	100	630	430	380	0	80	38	240	460	465	4	100	360	180	16	16	122
VE65-125	80	65	11	160M	1020/DA	1072	924	72,5	100	724	465	415	0	80	38	240	505	608	4	100	360	180	16	16	173
VE65-160	80	65	7,5	132S	1019/CA	929	830	82,5	100	630	430	380	0	80	38	240	460	465	4	100	360	200	16	16	122
VE65-160	80	65	11	160M	1020/DA	1072	924	72,5	100	724	465	415	0	80	38	240	505	608	4	100	360	200	16	16	173
VE65-160	80	65	15	160M	1020/DA	1072	924	72,5	100	724	465	415	0	80	38	240	505	608	4	100	360	200	16	16	173
VE65-200	80	65	18,5	160L	1015/DA	1116	994	82,5	100	794	470	420	0	100	38	280	545	652	4	100	360	225	16	16	205
VE65-200	80	65	22	180M	1016/EA	1154	990	82,5	100	790	490	440	0	80	38	260	540	690	4	100	360	225	16	16	245
VE65-200	80	65	30	200L	1017/FA	1224	1075	90,5	200	675	540	490	0	100	42	300	610	760	4	100	360	225	16	16	343
VE65-200	80	65	37	200L	1017/FA	1224	1075	90,5	200	675	540	490	0	100	42	300	610	760	4	100	360	225	16	16	362
VE65-250	80	65	30	200L	1021/FX	1334	1190	95	200	790	520	470	0	100	50	300	610	760	4	100	470	250	16	16	356
VE65-315	100	65	37	200L	2006/FX	1419	1227	95	200	827	560	510	0	100	38	325	635	760	4	125	530	280	16	16	392
VE65-315	100	65	45	225M	2007/FX	1464	1259	95	200	859	605	555	0	100	38	325	660	805	4	125	530	280	16	16	471
VE65-315	100	65	55	250M	2008/GX	1569	1386	90	200	986	655	605	0	120	42	370	745	910	4	125	530	280	16	16	570
VE65-315	100	65	75	280S	2009/HX	1644	1417	95	250	917	705	655	0	140	42	420	825	985	4	125	530	280	16	16	710
VE65-315	100	65	90	280M	2010/HX	1689	1468	95	250	968	705	655	0	140	42	420	825	1030	4	125	530	280	16	16	742
VE65-315	100	65	110	315S	2011/HX	1839	1481	95	250	981	800	750	0	160	50	475	1035	1180	4	125	530	280	16	16	1143
VE65-315	100	65	132	315M	2012/HX	1949	1583	95	250	1083	800	750	0	160	50	475	1035	1290	4	125	530	280	16	16	1194
VE65-315	100	65	160	315L	2012/IX	1949	1583	95	250	1083	800	750	0	160	50	475	1035	1290	4	125	530	280	16	16	1306
VE80-160	100	80	11	160M	1014/DA	1097	950	82,5	100	750	470	420	0	80	38	260	525	608	4	125	360	225	16	16	179
VE80-160	100	80	18,5	160L	1015/DA	1141	994	82,5	100	794	470	420	0	100	38	280	545	652	4	125	360	225	16	16	205
VE80-160	100	80	22	180M	1016/EA	1179	990	82,5	100	790	490	440	0	80	38	260	540	690	4	125	360	225	16	16	245
VE80-160	100	80	30	200L	1017/FA	1249	1075	90,5	200	675	540	490	0	100	42	300	610	760	4	125	360	225	16	16	296
VE80-200	100	80	15	160M	1023/DX	1207	1060	72,5	150	760	490	440	0	100	50	280	545	608	4	125	470	250	16	16	205
VE80-200	100	80	18,5	160L	1024/DX	1251	1104	92,5	150	804	490	440	0	100	50	280	545	652	4	125	470	250	16	16	230
VE80-200	100	80	22	180M	1025/EX	1289	1100	82,5	200	700	490	440	0	100	50	280	560	690	4	125	470	250	16	16	270
VE80-200	100	80	30	200L	1026/FX	1359	1203	92,5	200	803	540	490	0	100	42	300	610	760	4	125	470	250	16	16	365
VE80-200	100	80	37	200L	1026/FX	1359	1203	92,5	200	803	540	490	0	100	42	300	610	760	4	125	470	250	16	16	365
VE80-200	100	80	45	225M	1124/FX	1404	1207	92,5	200	807	585	535	0	100	42	325	660	805	4	125	470	250	16	16	398
VE80-250	100	80	37	200L	1027/FX	1359	1205	95	200	805	550	500	0	100	42	300	610	760	4	125	470	280	16	16	356

Pump DIMENSIONS

VE - 2P / 3000Rpm

COUPLINGS WITH STANDARDIZED ENCLOSED ELECTRIC MOTORS

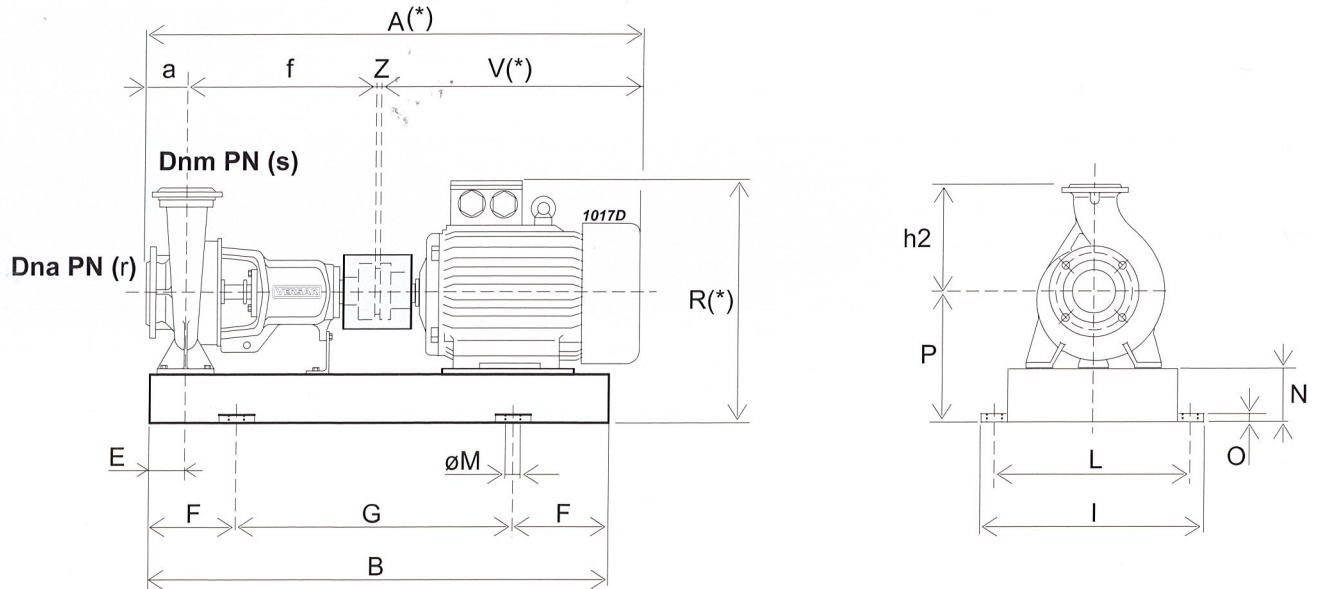

Pump Type		Motor		BGAN	A *	B	E	F	G	I	L	M	N	O	P	R *	V *	Z	a	f	h2	r	s	Weight	
Type	DNa [mm]	DNm [mm]	[kW] Size Grand.	Type	[mm]																				
VE80-250	100	80	45	225M	1028/FX	1404	1208	95	200	808	585	535	0	100	42	325	660	805	4	125	470	280	16	16	428
VE80-250	100	80	55	250M	1029/GX	1509	1321	107,5	250	821	635	585	0	120	42	370	745	910	4	125	470	280	16	16	535
VE80-250	100	80	75	280S	1030/HX	1584	1362	107,5	250	862	675	625	0	140	42	420	825	985	4	125	470	280	16	16	710
VE100-160	125	100	22	180M	1031/EX	1289	1133	95	200	733	510	460	0	100	42	300	580	690	4	125	470	250	16	16	271
VE100-160	125	100	37	200L	1021/FX	1359	1190	95	200	790	520	470	0	100	50	300	610	760	4	125	470	250	16	16	375
VE100-200	125	100	22	180M	1031/EX	1289	1133	95	200	733	510	460	0	100	42	300	580	690	4	125	470	280	16	16	271
VE100-200	125	100	75	280S	1125/HX	1584	1383	107,5	200	983	695	645	0	100	42	380	785	985	4	125	470	280	16	16	440
VE100-250	125	100	45	225M	1033/FX	1419	1236	95	200	836	585	535	0	100	42	325	660	805	4	140	470	280	16	16	440
VE100-250	125	100	55	250M	1034/GX	1524	1329	105	200	929	635	585	0	120	42	370	745	910	4	140	470	280	16	16	540
VE100-250	125	100	90	280M	1036/HE	1644	1434	107,5	250	934	695	645	0	140	42	420	825	1030	4	140	470	280	16	16	792
VE100-315	125	100	55	250M	2013/GX	1584	1356	95	200	956	655	605	0	120	42	370	745	910	4	140	530	315	16	16	585
VE100-315	125	100	75	280S	2014/HX	1659	1427	90	250	827	705	655	0	140	42	420	825	985	4	140	530	315	16	16	735
VE100-315	125	100	90	280M	2015/HX	1704	1478	90	250	978	705	655	0	140	42	420	825	1030	4	140	530	315	16	16	766
VE100-315	125	100	110	315S	2016/HX	1854	1481	95	250	981	800	750	0	160	50	475	1035	1180	4	140	530	315	16	16	1160
VE100-315	125	100	132	315M	2017/HX	1964	1598	110	250	1098	800	750	0	160	50	475	1035	1290	4	140	530	315	16	16	1213
VE100-315	125	100	160	315L	2017/IX	1964	1598	110	250	1098	800	750	0	160	50	475	1035	1290	4	140	530	315	16	16	1323
VE100-315	125	100	200	315L	2017/LX	1964	1598	110	250	1098	800	750	0	160	50	475	1035	1290	4	140	530	315	16	16	1413
VE125-200	150	125	55	250M	1094/GX	1524	1329	95	250	829	635	585	20	120	42	370	745	910	4	140	470	315	16	16	540
VE125-200	150	125	90	280M	1107/HE	1644	1398	95	250	898	695	645	0	140	45	420	825	1030	4	140	470	315	16	16	792
VE125-250	150	125	55	250M	2013/GX	1584	1356	95	200	956	655	605	0	120	42	370	745	910	4	140	530	355	16	16	590
VE125-250	150	125	75	280S	2014/HX	1659	1427	90	250	827	705	655	0	140	42	420	825	985	4	140	530	355	16	16	740
VE125-250	150	125	90	280M	2015/HX	1704	1478	90	250	978	705	655	0	140	42	420	825	1030	4	140	530	355	16	16	771
VE125-250	150	125	110	315S	2016/HX	1854	1481	95	250	981	800	750	0	160	50	475	1035	1180	4	140	530	355	16	16	1165
VE125-250	150	125	132	315M	2017/HX	1964	1598	110	250	1098	800	750	0	160	50	475	1035	1290	4	140	530	355	16	16	1218
VE125-250	150	125	160	315L	2017/IX	1964	1598	110	250	1098	800	750	0	160	50	475	1035	1290	4	140	530	355	16	16	1328
VE125-250	150	125	200	315L	2017/LX	1964	1598	110	250	1098	800	750	0	160	50	475	1035	1290	4	140	530	355	16	16	1418

BGAN = Base and coupling

* = Indicatives values according to the type of motor installed.

Pump DIMENSIONS

VE - 4P / 1500Rpm

COUPLINGS WITH STANDARDIZED ENCLOSED ELECTRIC MOTORS

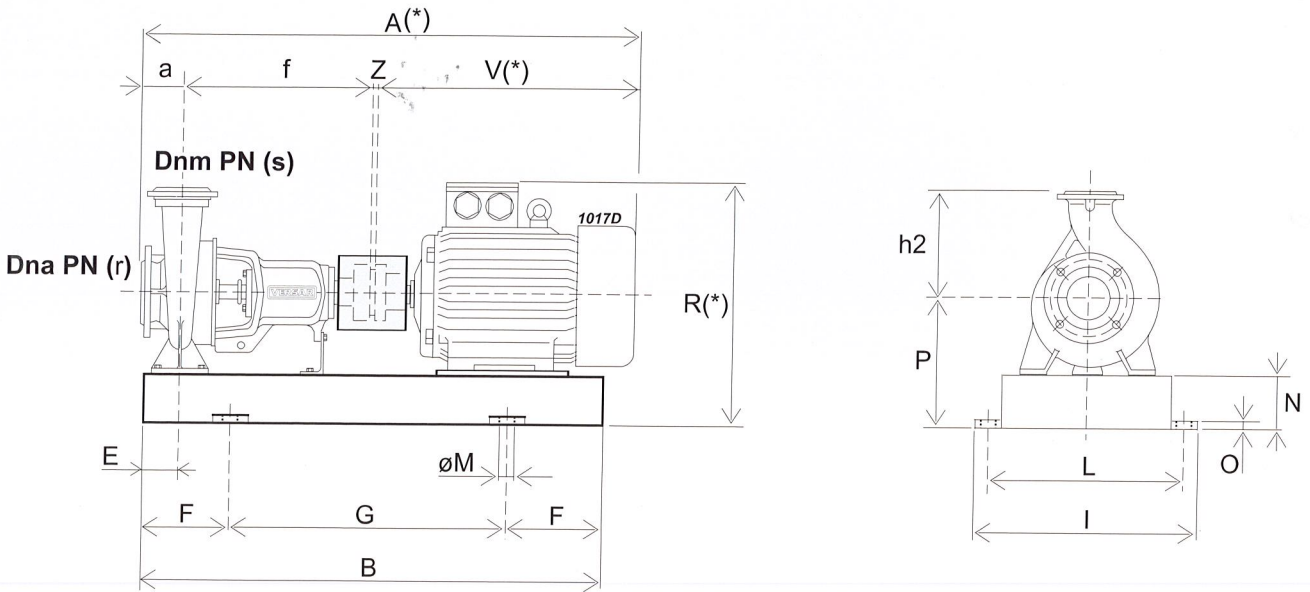

Pump Type		Motor		BGAN	A *	B	E	F	G	I	L	M	N	O	P	R *	V *	Z	a	f	h2	r	s	Weight	
Type	DNa	DNm	[kW]	Type	[mm]																				
	[mm]	[mm]	kW		Size Grand.																				
VE32-160	50	32	0,75	80M	1040/CA	724	659	60	100	459	390	340	0	80	38	212	357	280	4	80	360	160	16	16	60
VE32-160	50	32	1,1	90S	1041/CA	759	710	60	100	510	390	340	0	80	38	212	367	315	4	80	360	160	16	16	68
VE32-200	50	32	0,75	80M	1042/CA	724	689	60	100	489	390	340	0	80	38	240	385	280	4	80	360	180	16	16	67
VE32-200	50	32	1,1	90S	1043/CA	759	710	60	100	510	390	340	0	80	38	240	395	315	4	80	360	180	16	16	73
VE32-250	50	32	4	112M	1051/CA	864	787	82,5	150	487	470	420	0	80	38	260	450	400	4	100	360	225	16	16	108
VE40-160	65	40	0,75	80M	1040/CA	724	659	60	100	459	390	340	0	80	38	212	357	280	4	80	360	160	16	16	60
VE40-160	65	40	1,1	90S	1041/CA	759	710	60	100	510	390	340	0	80	38	212	367	315	4	80	360	160	16	16	68
VE40-200	65	40	0,75	80M	1047/CA	744	689	60	100	489	415	365	0	80	38	240	385	280	4	100	360	180	16	16	73
VE40-200	65	40	1,1	90S	1048/CA	779	675	60	100	475	415	365	0	80	38	240	395	315	4	100	360	180	16	16	79
VE40-200	65	40	1,5	90L	1049/CA	804	700	60	100	500	415	365	0	80	38	240	395	340	4	100	360	180	16	16	79
VE40-250	65	40	2,2	100L	1050/CA	839	774	72,5	150	474	470	420	0	80	38	260	440	375	4	100	360	225	16	16	99
VE40-250	65	40	3	100L	1050/CA	839	774	72,5	150	474	470	420	0	80	38	260	440	375	4	100	360	225	16	16	99
VE40-250	65	40	4	112M	1051/CA	864	787	82,5	150	487	470	420	0	80	38	260	450	400	4	100	360	225	16	16	108
VE40-315	65	40	4	112M	1053/DX	999	897	82,5	100	697	495	445	0	100	42	300	490	400	4	125	470	225	16	16	175
VE40-315	65	40	5,5	132S	1054/DX	1064	941	82,5	150	641	495	445	0	100	42	300	520	465	4	125	470	225	16	16	205
VE40-315	65	40	7,5	132M	1055/DX	1104	980	82,5	150	680	495	445	0	100	42	300	520	505	4	125	470	225	16	16	205
VE40-315	65	40	11	160M	1056/EX	1207	1060	82,5	150	760	495	445	0	100	42	300	565	608	4	125	470	225	16	16	245
VE50-125	65	50	0,75	80M	1040/CA	744	659	60	100	459	390	340	0	80	38	212	357	280	4	100	360	160	16	16	60
VE50-160	65	50	0,75	80M	1047/CA	744	689	60	100	489	415	365	0	80	38	240	385	280	4	100	360	180	16	16	73
VE50-160	65	50	1,1	90S	1048/CA	779	675	60	100	475	415	365	0	80	38	240	395	315	4	100	360	180	16	16	79
VE50-160	65	50	1,5	90L	1049/CA	804	700	60	100	500	415	365	0	80	38	240	395	340	4	100	360	180	16	16	79
VE50-200	65	50	1,1	90S	1048/CA	779	675	60	100	475	415	365	0	80	38	240	395	315	4	100	360	200	16	16	78
VE50-250	65	50	4	112M	1051/CA	864	787	82,5	150	487	470	420	0	80	38	260	450	400	4	100	360	225	16	16	108
VE50-315	65	50	4	112M	1132/DX	999	897	82,5	100	697	495	445	0	100	42	325	515	400	4	125	470	280	16	16	175
VE50-315	65	50	5,5	132S	1133/DX	1064	941	82,5	150	641	495	445	0	100	42	325	545	465	4	125	470	280	16	16	205
VE50-315	65	50	7,5	132M	1134/DX	1104	974	82,5	150	674	510	460	0	100	42	325	545	505	4	125	470	280	16	16	205
VE50-315	65	50	11	160M	1135/EX	1207	1055	82,5	150	655	510	460	0	100	42	325	590	608	4	125	470	280	16	16	245
VE65-125	80	65	0,75	80M	1152/CA	744	702	72,5	150	402	430	380	0	80	38	240	385	280	4	100	360	180	16	16	70
VE65-125	80	65	1,1	90S	1153/CA	779	723	72,5	150	423	430	380	0	80	38	240	395	315	4	100	360	180	16	16	76
VE65-160	80	65	0,75	80M	1057/CA	744	702	72,5	150	402	430	380	0	80	38	240	385	280	4	100	360	200	16	16	75
VE65-160	80	65	1,1	90S	1058/CA	779	687	72,5	150	387	430	380	0	80	38	240	395	315	4	100	360	200	16	16	81
VE65-160	80	65	1,5	90L	1059/CA	804	748	72,5	150	448	430	380	0	80	38	240	395	340	4	100	360	200	16	16	81
VE65-160	80	65	2,2	100L	1060/CA	839	777	72,5	150	477	430	380	0	80	38	240	420	375	4	100	360	200	16	16	90
VE65-200	80	65	1,5	90L	1061/CA	804	748	72,5	150	448	470	420	0	80	38	260	415	340	4	100	360	225	16	16	84
VE65-200	80	65	2,2	100L	1050/CA	839	774	72,5	150	474	470	420	0	80	38	260	440	375	4	100	360	225	16	16	99
VE65-200	80	65	3	100L	1050/CA	839	774	72,5	150	474	470	420	0	80	38	260	440	375	4	100	360	225	16	16	99
VE65-200	80	65	4	112M	1051/CA	864	787	82,5	150	487	470	420	0	80	38	260	450	400	4	100	360	225	16	16	108

Pump DIMENSIONS

VE - 4P / 1500Rpm

COUPLINGS WITH STANDARDIZED ENCLOSED ELECTRIC MOTORS

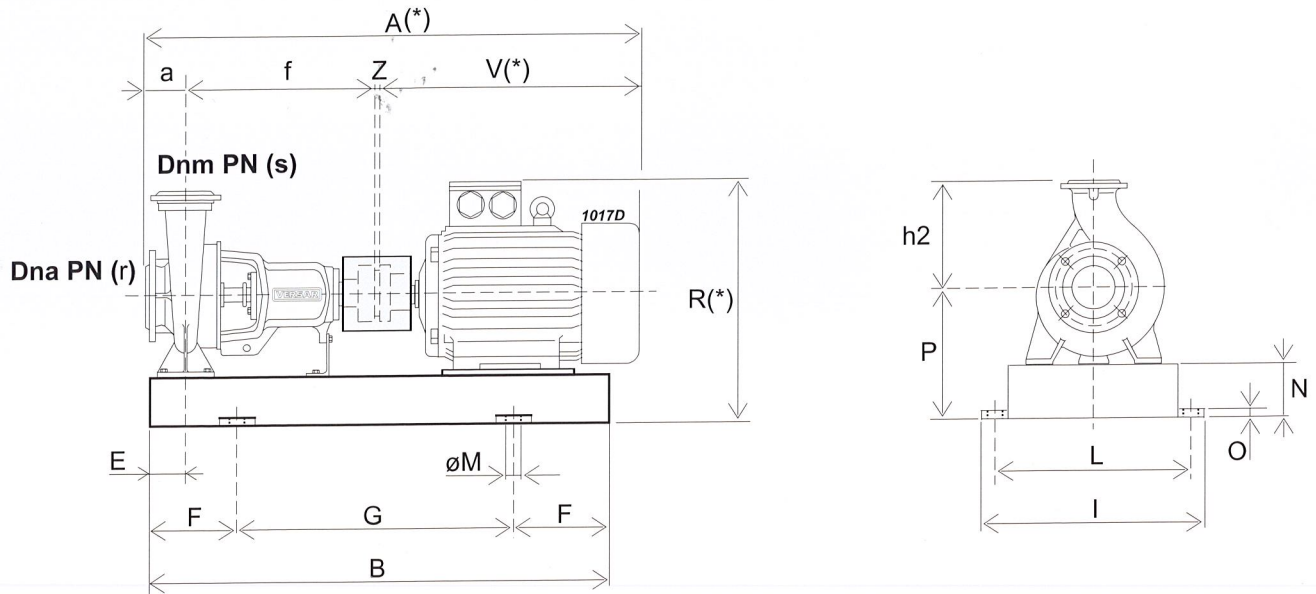

Pump Type			Motor		BGAN	A *	B	E	F	G	I	L	M	N	O	P	R *	V *	Z	a	f	h2	r	s	Weight	
Type	DNa [mm]	DNm [mm]	[kW] kW	Size Grand.	Type	[mm]																				
VE65-250	80	65	3	100L	1062/DX	949	905	95	200	505	510	460	0	100	42	300	480	375	4	100	470	250	16	16	132	
VE65-250	80	65	4	112M	1063/DX	974	914	95	200	514	510	460	0	100	42	300	490	400	4	100	470	250	16	16	142	
VE65-250	80	65	5.5	132S	1064/DX	1039	958	95	200	558	510	460	0	100	42	300	520	465	4	100	470	250	16	16	174	
VE65-315	80	65	5.5	132S	1066/DX	1064	958	95	150	658	600	550	0	100	42	325	545	465	4	125	470	280	16	16	210	
VE65-315	80	65	7.5	132M	1067/DX	1104	997	95	150	697	550	500	0	100	42	325	545	505	4	125	470	280	16	16	210	
VE65-315	80	65	11	160M	1068/EX	1207	1068	95	150	768	550	500	0	100	42	325	590	608	4	125	470	280	16	16	268	
VE80-160	100	80	1.1	90S	1070/CA	804	723	72.5	150	423	470	420	0	80	38	260	415	315	4	125	360	225	16	16	84	
VE80-160	100	80	1.5	90L	1061/CA	829	748	72.5	150	448	470	420	0	80	38	260	415	340	4	125	360	225	16	16	84	
VE80-160	100	80	2.2	100L	1050/CA	864	774	72.5	150	474	470	420	0	80	38	260	440	375	4	125	360	225	16	16	99	
VE80-160	100	80	3	100L	1050/CA	864	774	72.5	150	474	470	420	0	80	38	260	440	375	4	125	360	225	16	16	99	
VE80-200	100	80	2.2	100L	1071/DX	974	887	82.5	200	487	495	445	0	80	38	260	440	375	4	125	470	250	16	16	120	
VE80-200	100	80	3	100L	1071/DX	974	887	82.5	200	487	495	445	0	80	38	260	440	375	4	125	470	250	16	16	120	
VE80-200	100	80	4	112M	1072/DX	999	897	82.5	200	497	495	445	0	80	38	260	450	400	4	125	470	250	16	16	125	
VE80-200	100	80	7.5	132M	1074/DX	1104	963	82.5	150	663	490	440	0	100	50	280	500	505	4	125	470	250	16	16	155	
VE80-250	100	80	5.5	132S	1075/DX	1064	958	95	200	558	550	500	0	100	42	300	520	465	4	125	470	280	16	16	174	
VE80-250	100	80	7.5	132M	1076/DX	1104	996	95	200	596	550	500	0	100	42	300	520	505	4	125	470	280	16	16	174	
VE80-250	100	80	11	160M	1077/EX	1207	1040	95	250	540	550	500	0	100	42	300	565	608	4	125	470	280	16	16	228	
VE80-250	100	80	15	160L	1078/EX	1251	1122	95	250	622	550	500	0	100	42	300	565	652	4	125	470	280	16	16	228	
VE80-315	100	80	7.5	132M	1079/DX	1104	997	95	250	497	550	500	0	120	42	370	590	505	4	125	470	315	16	16	235	
VE80-400	100	80	18.5	180M	1091/FY	1351	1195	95	250	695	590	540	0	140	45	420	700	690	4	125	532	355	16	16	400	
VE100-160	125	100	3	100L	1062/DX	974	905	95	200	505	510	460	0	100	42	300	480	375	4	125	470	250	16	16	132	
VE100-160	125	100	4	112M	1063/DX	999	914	95	200	514	510	460	0	100	42	300	490	400	4	125	470	250	16	16	142	
VE100-160	125	100	5.5	132S	1064/DX	1064	958	95	200	558	510	460	0	100	42	300	520	465	4	125	470	250	16	16	174	
VE100-160	125	100	7.5	132M	1065/DX	1104	986	95	200	586	510	460	0	100	42	300	520	505	4	125	470	250	16	16	174	
VE100-200	125	100	3	100L	1062/DX	974	905	95	200	505	510	460	0	100	42	300	480	375	4	125	470	280	16	16	132	
VE100-200	125	100	4	112M	1063/DX	999	914	95	200	514	510	460	0	100	42	300	490	400	4	125	470	280	16	16	142	
VE100-200	125	100	5.5	132S	1064/DX	1064	958	95	200	558	510	460	0	100	42	300	520	465	4	125	470	280	16	16	174	
VE100-250	125	100	5.5	132S	1066/DX	1079	958	95	150	658	600	550	0	100	42	325	545	465	4	140	470	280	16	16	210	
VE100-250	125	100	7.5	132M	1067/DX	1119	997	95	150	697	550	500	0	100	42	325	545	505	4	140	470	280	16	16	210	
VE100-250	125	100	11	160M	1068/EX	1222	1068	95	150	768	550	500	0	100	42	325	590	608	4	140	470	280	16	16	268	
VE100-315	125	100	11	160M	1080/EX	1222	1077	95	250	577	550	500	0	120	42	370	635	608	4	140	470	315	16	16	297	
VE100-400	125	100	22	180L	1084/FY	1404	1224	110	250	724	650	600	0	140	45	420	700	730	4	140	530	355	16	16	465	
VE100-400	125	100	30	200L	1085/GY	1434	1262	110	250	762	650	600	0	140	45	420	730	760	4	140	530	355	16	16	535	
VE100-400	125	100	45	225M	1087/HY	1509	1314	110	300	714	640	590	0	140	42	420	755	835	4	140	530	355	16	16	624	
VE100-400	125	100	55	250M	1088/HY	1584	1409	110	300	809	650	600	0	140	45	420	795	910	4	140	530	355	16	16	762	
VE125-200	150	125	7.5	132M	1079/DX	1119	997	95	250	497	550	500	0	120	42	370	590	505	4	140	470	315	16	16	235	
VE125-200	150	125	11	160M	1080/EX	1222	1077	95	250	577	550	500	0	120	42	370	635	608	4	140	470	315	16	16	297	

Pump DIMENSIONS

VE - 4P / 1500Rpm

COUPLINGS WITH STANDARDIZED ENCLOSED ELECTRIC MOTORS

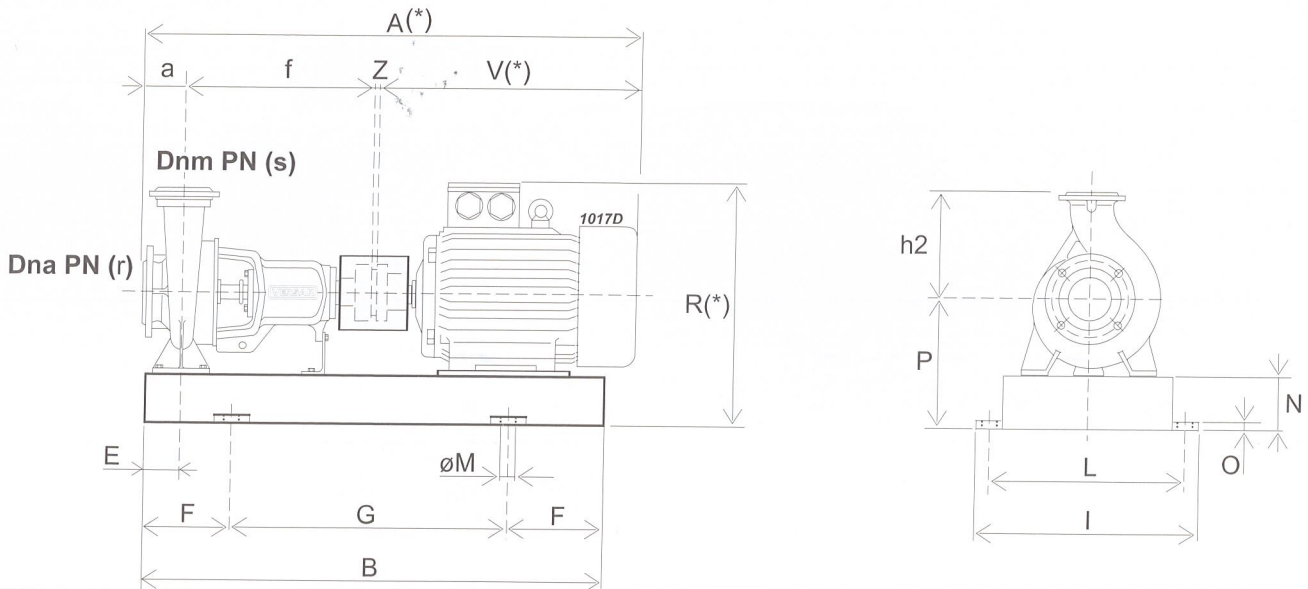

Pump Type		Motor		BGAN	A *	B	E	F	G	I	L	M	N	O	P	R *	V *	Z	a	f	h2	r	s	Weight	
Type	DNa	DNm	[kW]	Type	[mm]																				
	[mm]	[mm]	kW		Size Grand.																				
VE125-200	150	125	15	160L	1081/EX	1266	1121	95	250	621	550	500	0	120	42	370	635	652	4	140	470	315	16	16	297
VE125-200	150	125	18,5	180M	1082/FX	1304	1111	95	250	611	550	500	0	120	42	370	650	690	4	140	470	315	16	16	343
VE125-200	150	125	22	180L	1083/FX	1344	1149	95	250	649	550	500	0	120	42	370	650	730	4	140	470	315	16	16	343
VE125-250	150	125	22	180L	1083/FX	1344	1149	95	250	649	550	500	0	120	42	370	650	730	4	140	470	355	16	16	340
VE125-315	150	125	15	160L	1090/EY	1326	1202	110	250	702	650	600	0	140	45	420	685	652	4	140	530	355	16	16	355
VE125-315	150	125	18,5	180M	1154/FY	1364	1213	110	250	713	650	600	0	140	45	420	700	690	4	140	530	355	16	16	405
VE125-315	150	125	22	180L	1084/FY	1404	1224	110	250	724	650	600	0	140	45	420	700	730	4	140	530	355	16	16	465
VE125-315	150	125	30	200L	1085/GY	1434	1262	110	250	762	650	600	0	140	45	420	730	760	4	140	530	355	16	16	535
VE125-315	150	125	45	225M	1087/HY	1509	1314	110	300	714	640	590	0	140	42	420	755	835	4	140	530	355	16	16	624
VE125-400	150	125	45	225M	1096/HY	1509	1314	110	300	714	650	600	0	160	50	475	810	835	4	140	530	400	16	16	640
VE125-400	150	125	55	250M	1097/HY	1584	1409	110	300	809	650	600	0	160	45	475	850	910	4	140	530	400	16	16	762
VE125-400	150	125	75	280S	1098/IY	1679	1412	110	300	812	700	650	0	160	50	475	880	1005	4	140	530	400	16	16	925
VE150-200	200	150	11	160M	1129/EX	1267	1122	110	250	622	700	650	0	140	45	420	685	608	4	160	495	400	16	16	435
VE150-200	200	150	15	160L	1130/EX	1311	1151	110	250	651	700	650	0	140	45	420	685	652	4	160	495	400	16	16	450
VE150-200	200	150	18,5	180M	1131/FY	1349	1181	110	250	681	700	650	0	140	45	420	700	690	4	160	495	400	16	16	490
VE150-200	200	150	22	180L	1099/FX	1389	1215	110	250	715	700	650	0	140	45	420	700	730	4	160	495	400	16	16	495
VE150-250	200	150	18,5	180M	1136/FY	1384	1201	110	250	701	600	550	0	120	42	370	650	690	4	160	530	355	16	16	400
VE150-250	200	150	22	180L	1137/FY	1424	1244	110	250	744	600	550	0	120	42	370	650	730	4	160	530	355	16	16	400
VE150-250	200	150	30	200L	1151/GY	1454	1252	110	250	752	600	550	0	140	45	390	700	760	4	160	530	355	16	16	470
VE150-315	200	150	22	180L	1138/FY	1424	1250	110	250	713	700	650	0	140	45	420	700	730	4	160	530	400	16	16	495
VE150-315	200	150	30	200L	1100/GX	1454	1262	110	250	762	700	650	0	140	45	420	730	760	4	160	530	400	16	16	556
VE150-315	200	150	37	225S	1101/GX	1504	1290	110	300	690	700	650	0	140	45	420	755	810	4	160	530	400	16	16	650
VE150-400	200	150	45	225M	1139/HY	1529	1346	110	300	746	700	650	0	160	50	475	810	835	4	160	530	450	16	16	665
VE150-400	200	150	55	250M	1140/HY	1604	1409	110	300	809	700	650	0	160	50	475	850	910	4	160	530	450	16	16	787
VE150-400	200	150	90	280M	1105/IY	1754	1503	110	300	903	700	650	0	160	50	475	880	1060	4	160	530	450	16	16	1040
VE150-400	200	150	110	315S	1106/LY	1904	1578	110	300	978	780	730	0	160	50	475	1035	1210	4	160	530	450	16	16	1180
VE150-500	200	150	45	225M	2018/GY2	1669	1529	160	250	1029	720	670	0	200	50	600	935	835	4	160	670	500	16	16	863
VE150-500	200	150	55	250M	2019/HY2	1744	1586	160	250	1086	720	670	0	200	50	600	975	910	4	160	670	500	16	16	925
VE150-500	200	150	75	280S	2020/IY2	1839	1627	160	250	1127	720	670	0	200	50	600	1005	1005	4	160	670	500	16	16	1056
VE150-500	200	150	90	280M	2021/IY2	1894	1678	160	300	1078	720	670	0	200	50	600	1005	1060	4	160	670	500	16	16	991
VE150-500	200	150	110	315S	2022/LY2	2044	1751	160	300	1151	800	750	0	200	50	600	1160	1210	4	160	670	500	16	16	1480
VE150-500	200	150	132	315M	2023/MY2	2154	1802	160	300	1202	800	750	0	200	50	600	1160	1320	4	160	670	500	16	16	1629
VE150-500	200	150	160	315L	2023/MY2	2154	1802	160	300	1202	800	750	0	200	50	600	1160	1320	4	160	670	500	16	16	1629
VE150-500	200	150	200	315L	2023/MY2	2154	1802	160	300	1202	800	750	0	200	50	600	1160	1320	4	160	670	500	16	16	1740
VE200-250	250	200	30	200L	1108/GY	1497	1308	110	300	708	700	650	0	160	50	475	785	760	4	180	553	450	16	16	567
VE200-250	250	200	37	225S	1109/GY	1547	1344	110	300	744	700	650	0	160	50	475	810	810	4	180	553	450	16	16	613
VE200-250	250	200	45	225M	1141/HY	1572	1369	110	300	769	700	650	0	160	50	475	810	835	4	180	553	450	16	16	667

Pump DIMENSIONS

VE - 4P / 1500Rpm

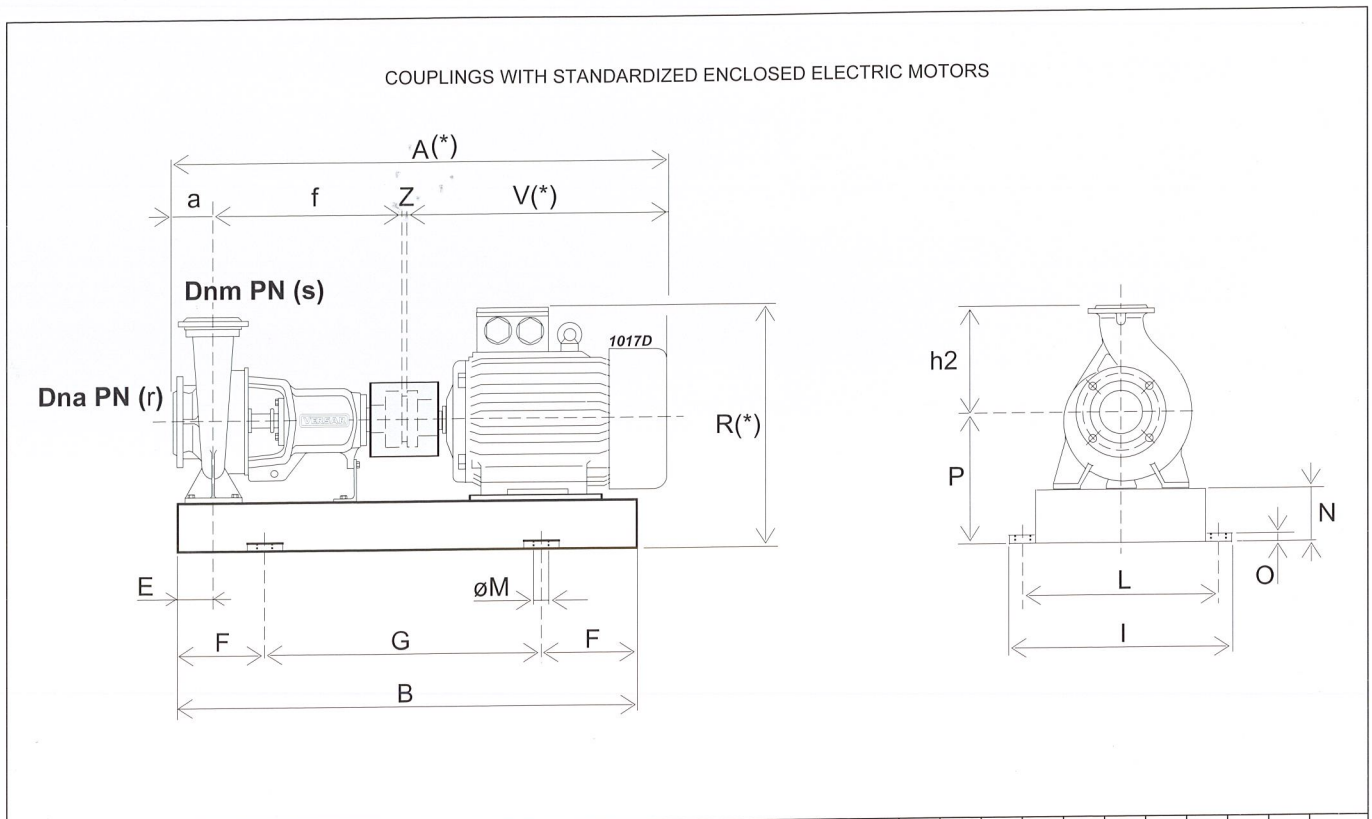

Pump Type		Motor		BGAN	A *	B	E	F	G	I	L	M	N	O	P	R *	V *	Z	a	f	h2	r	s	Weight	
Type	DNa [mm]	DNm [mm]	[kW] kW	Size Grand.	Type	[mm]																			
VE200-250	250	200	55	250M	1110/HY	1647	1432	110	300	832	700	650	0	160	50	475	850	910	4	180	553	450	16	16	726
VE200-315	250	200	30	200L	1111/GY2	1614	1422	120	250	922	750	700	0	160	50	475	785	760	4	180	670	480	16	16	662
VE200-315	250	200	37	225S	1112/GY2	1664	1464	120	300	864	750	700	0	160	45	475	810	810	4	180	670	480	16	16	740
VE200-400	250	200	75	280S	1116/IY2	1859	1568	120	300	968	750	700	0	160	50	495	900	1005	4	180	670	480	16	16	1003
VE200-400	250	200	90	280M	1117/IY2	1914	1613	120	300	1013	750	700	0	160	50	495	900	1060	4	180	670	480	16	16	1092
VE200-400	250	200	132	315M	1120/LY2	2174	1707	120	300	1107	750	700	0	160	50	495	1055	1320	4	180	670	480	16	16	1340
VE250-315	300	250	30	200L	1142/GY2	1675	1468	135	250	968	810	760	0	180	50	535	845	760	4	220	691	520	16	16	622
VE250-315	300	250	37	225S	1143/GY2	1725	1507	135	300	907	810	760	0	180	50	535	870	810	4	220	691	520	16	16	740
VE250-315	300	250	45	225M	1144/HY2	1750	1510	135	300	910	810	760	0	180	50	535	870	835	4	220	691	520	16	16	740
VE250-315	300	250	55	250M	1145/HY2	1825	1595	135	300	995	810	760	0	180	50	535	910	910	4	220	691	520	16	16	842
VE250-315	300	250	75	280S	1146/IY2	1920	1648	135	300	1048	810	760	0	180	50	535	940	1005	4	220	691	520	16	16	1000
VE250-400	300	250	75	280S	1147/IY2	1911	1640	135	300	1040	810	760	0	200	50	600	1005	1005	4	220	682	560	16	16	1003
VE250-400	300	250	90	280M	1148/IY2	1966	1690	135	300	1090	810	760	0	200	50	600	1005	1060	4	220	682	560	16	16	1092
VE250-400	300	250	110	315S	1149/LY2	2116	1733	135	300	1133	810	760	0	200	50	600	1160	1210	4	220	682	560	16	16	1240

Flange Dimensions

VE MODEL

Flanges (UNI EN 1092-2)

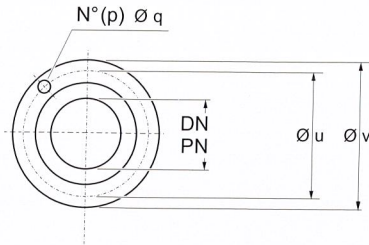

Port \varnothing		Holes		$\varnothing u$	$\varnothing v$
DN [mm]	PN [bar]	p No	q \varnothing [mm]	[mm]	
32	16	4	18	100	140
40	16	4	18	110	150
50	16	4	18	125	165
50	25	4	18	125	165
65	16	8	18	145	185
80	16	8	18	160	200
80	25	8	18	160	200
100	16	8	18	180	220
125	16	8	18	210	250
150	16	8	22	240	285
200	16	12	22	295	340
250	16	12	26	355	405
300	16	12	26	410	460

VERSAR®

The best solution for fluid control

VERSAR INDUSTRIAL WATER PUMPS

#470 North Bridge Road,

#05-12 Bugis Cube, Singapore 188735.

Email: sales@versar.com.sg

www.versar.com.sg

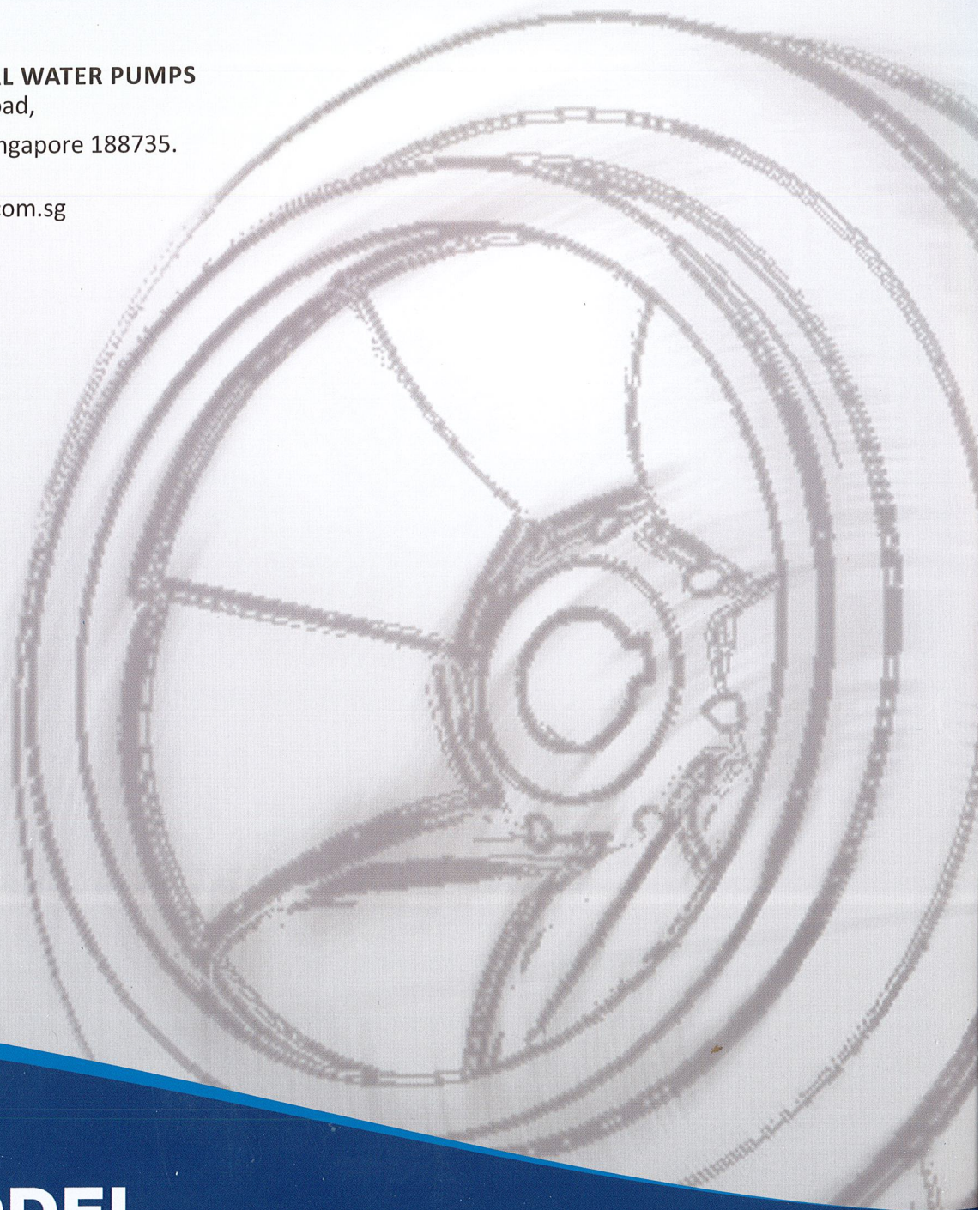

VE MODEL